



www.FGWilson.com

P150-1



Image for illustration purposes only.

Output Ratings

| Generating Set Model | Prime* | Standby* |
|----------------------|----------------------|----------------------|
| 380-415V, 50Hz | 135.0 kVA / 108.0 kW | 150.0 kVA / 120.0 kW |
| 480V, 60 Hz | 150.0 kVA / 120.0 kW | 165.0 kVA / 132.0 kW |

Ratings at 0.8 power factor.

Prime Rating

These ratings are applicable for supplying continuous electrical power (at variable load) in lieu of commercially purchased power. There is no limitation to the annual hours of operation and this model can supply 10% overload power for 1 hour in 12 hours.

Standby Rating

These ratings are applicable for supplying continuous electrical power (at variable load) in the event of a utility power failure. No overload is permitted on these ratings. The alternator on this model is peak continuous rated (as defined in ISO 8528-3).

Standard Reference Conditions

Note: Standard reference conditions 25°C (77°F) Air Inlet Temp, 100m (328 ft) A.S.L. 30% relative humidity.
Fuel consumption data at full load with diesel fuel with specific gravity of 0.85 and conforming to BS2869: 1998, Class A2.

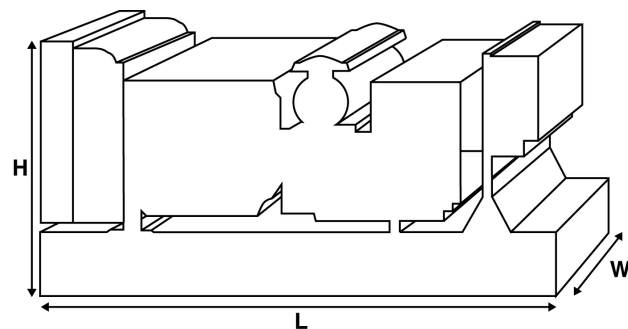

Ratings and Performance Data

| | | |
|---|-----------------|-------------|
| Engine Make & Model: | Perkins 1006TAG | |
| Alternator manufactured for FG Wilson by: | Leroy Somer | |
| Alternator Model: | LL3014F | |
| Control Panel: | PowerWizard 1.1 | |
| Base Frame: | Fbc2 - (08Hr) | |
| Circuit Breaker Type: | 3 Pole MCCB | |
| Frequency: | 50 Hz | 60 Hz |
| Engine Speed: RPM | 1500 | 1800 |
| Fuel Tank Capacity: litres (US gal) | 349 (92.2) | |
| Fuel Consumption: l/hr (US gal/hr) (100% Load) | Prime | Standby |
| | 31.2 (8.2) | 38.2 (10.1) |
| | 34.4 (9.1) | 41.5 (11.0) |

Available Options

- I CE Certification
- I Sound Attenuated EC Enclosures
- I Control Panel Upgrades
- I Range of Silencers
- I Range of Remote Fuel Systems
- I Range of Alarms and Shutdowns

Dimensions and Weights

| Length (L) mm (in) | Width (W) mm (in) | Height (H) mm (in) | Dry kg (lb) | Wet kg (lb) |
|-----------------------|----------------------|---------------------------------|----------------|----------------|
| 2500 (98.4) | 1120 (44.1) | 1470 (57.9) | 1602 (3533) | 1640 (3616) |
| Dry = With Lube Oil | | Wet = With Lube Oil and Coolant | | |

Ratings in accordance with ISO 8528, ISO 3046, IEC 60034, BS5000 and NEMA MG-1/22. Generating set pictured may include optional accessories.

FG Wilson has manufacturing facilities in the following locations:

Northern Ireland • Brazil • China • India • USA

With headquarters in Northern Ireland, FG Wilson operates through a Global Dealer Network.

To contact your local Sales Office please visit the FG Wilson website at www.FGWilson.com

| Engine Technical Data | | |
|--|---------------------------------------|------------|
| No. of Cylinders / Alignment: | 6 / In Line | |
| Cycle: | 4 Stroke | |
| Bore / Stroke: mm (in) | 100.0 (3.9)/127.0 (5.0) | |
| Induction: | Turbocharged Air To Air Charge Cooled | |
| Cooling Method: | Water | |
| Governing Type: | Electronic | |
| Governing Class: | ISO 8528 G2 | |
| Compression Ratio: | 17.0:1 | |
| Displacement: l (cu. in) | 6.0 (365.5) | |
| Moment of Inertia: kg m ² (lb/in ²) | 1.61 (5502) | |
| Engine Electrical System: | | |
| - Voltage / Ground | 12/Negative | |
| - Battery Charger Amps | 55 | |
| Weight: kg (lb) | - Dry | 586 (1292) |
| | - Wet | 630 (1389) |

| Performance | 50 Hz | 60 Hz |
|-----------------------------|----------------|----------------|
| Engine Speed: rpm | 1500 | 1800 |
| Gross Engine Power: kW (hp) | | |
| - Prime | 134.6 (181.0) | 150.0 (201.0) |
| - Standby | 145.8 (196.0) | 163.5 (219.0) |
| BMEP: kPa (psi) | | |
| - Prime | 1800.0 (261.0) | 1671.0 (242.3) |
| - Standby | 1949.0 (282.7) | 1822.0 (264.2) |

| Fuel System | | | | | |
|------------------------------------|---------------------|-------------|------------|------------|--|
| Fuel Filter Type: | Replaceable Element | | | | |
| Recommended Fuel: | Class A2 Diesel | | | | |
| Fuel Consumption: l/hr (US gal/hr) | | | | | |
| | 110% | 100% | 75% | 50% | |
| Prime | Load | Load | Load | Load | |
| 50 Hz | 34.4 (9.1) | 31.2 (8.2) | 24.2 (6.4) | 17.4 (4.6) | |
| 60 Hz | 41.5 (11.0) | 38.2 (10.1) | 30.0 (7.9) | 21.7 (5.7) | |
| | 110% | 100% | 75% | 50% | |
| Standby | Load | Load | Load | Load | |
| 50 Hz | | 34.4 (9.1) | 26.5 (7.0) | 18.9 (5.0) | |
| 60 Hz | | 41.5 (11.0) | 32.5 (8.6) | 23.4 (6.2) | |

(Based on diesel fuel with a specific gravity of 0.84 and conforming to BS2869, Class A2)

| Air Systems | 50 Hz | 60 Hz |
|---|---------------------|------------|
| Air Filter Type: | Replaceable Element | |
| Combustion Air Flow: m ³ /min (cfm) | | |
| - Prime | 8.4 (296) | 10.7 (379) |
| - Standby | 8.8 (310) | 11.2 (394) |
| Max. Combustion Air Intake Restriction: kPa (in H ₂ O) | 5.0 (20.1) | 5.0 (20.1) |

| Cooling System | 50 Hz | 60 Hz | |
|---|--------------|--------------|-------------|
| Cooling System Capacity: l (US gal) | 37.2 (9.8) | 37.2 (9.8) | |
| Water Pump Type: Centrifugal | | | |
| Heat Rejected to Water & Lube Oil: | | | |
| kW (Btu/min) | - Prime | 65.5 (3725) | 68.0 (3867) |
| | - Standby | 70.0 (3981) | 76.7 (4362) |
| Heat Radiation to Room: Heat radiated from engine and alternator | | | |
| kW (Btu/min) | - Prime | 15.4 (876) | 19.0 (1081) |
| | - Standby | 25.7 (1462) | 33.6 (1911) |
| Radiator Fan Load: kW (hp) | 4.5 (6.0) | 8.0 (10.7) | |
| Radiator Cooling Airflow: m ³ /min (cfm) | 192.0 (6780) | 244.0 (8617) | |
| External Restriction to Cooling Airflow: Pa (in H ₂ O) | | | |
| | 125 (0.5) | 125 (0.5) | |

Cooling system designed to operate in ambient conditions up to 50°C (122°F). Contact your local FG Wilson Dealer for power ratings at specific site conditions.

| Lubrication System | |
|--------------------------------|--------------------|
| Oil Filter Type: | Spin-On, Full Flow |
| Total Oil Capacity: l (US gal) | 19.0 (5.0) |
| Oil Pan: l (US gal) | 16.0 (4.2) |
| Oil Type: | API CD 15W-40 |
| Oil Cooling Method: | Water |

| Exhaust System | 50 Hz | 60 Hz |
|---|--------------|--------------|
| Silencer Type: | Industrial | |
| Silencer Model & Quantity: | SD100 (1) | |
| Pressure Drop Across Silencer System: kPa (in Hg) | | |
| | 4.00 (1.181) | 4.00 (1.181) |
| Silencer Noise Reduction Level: dB | 12 | 12 |
| Maximum Allowable Back Pressure: kPa (in Hg) | | |
| | 6.0 (1.8) | 6.0 (1.8) |
| Exhaust Gas Flow: m ³ /min (cfm) | | |
| - Prime | 24.0 (848) | 29.8 (1051) |
| - Standby | 25.7 (908) | 31.4 (1109) |
| Exhaust Gas Temperature: °C (°F) | | |
| - Prime | 571 (1060) | 540 (1004) |
| - Standby | 585 (1085) | 551 (1024) |

| Alternator Physical Data | |
|--------------------------------|-------------|
| Manufactured for FG Wilson by: | Leroy Somer |
| Model: | LL3014F |
| No. of Bearings: | 1 |
| Insulation Class: | H |
| Winding Pitch Code: | 2/3 - 6 |
| Wires: | 12 |
| Ingress Protection Rating: | IP23 |
| Excitation System: | SHUNT |
| AVR Model: | R250 |

| Alternator Operating Data | |
|------------------------------------|---|
| Overspeed: rpm | 2250 |
| Voltage Regulation: (Steady state) | +/- 0.5 |
| Wave Form NEMA = TIF: | 50 |
| Wave Form IEC = THF: | 2.0% |
| Total Harmonic content LL/LN: | 4.0% |
| Radio Interference: | Suppression is in line with European Standard EN61000-6 |
| Radiant Heat: kW (Btu/min) | |
| - 50 Hz | 10.2 (580) |
| - 60 Hz | 11.3 (643) |

| Alternator Performance Data: | 50 Hz | | | | 60 Hz | | | | |
|--------------------------------|----------|----------|----------|----------|----------|----------|----------|----------|----------|
| | 415/240V | 400/230V | 380/220V | 220/127V | 480/277V | 380/220V | 240/120V | 230/115V | 440/254V |
| Data Item | | | | | | | | | |
| Motor Starting Capability* kVA | 329 | 309 | 283 | 362 | 360 | 241 | 283 | 264 | 311 |
| Short Circuit Capacity** % | 300 | 300 | 300 | 300 | 300 | 300 | 300 | 300 | 300 |
| Reactances: Per Unit | | | | | | | | | |
| Xd | 2.640 | 2.850 | 3.150 | 2.180 | 2.640 | 4.200 | 3.510 | 3.790 | 3.140 |
| X'd | 0.090 | 0.100 | 0.110 | 0.080 | 0.090 | 0.150 | 0.120 | 0.130 | 0.110 |
| X''d | 0.055 | 0.059 | 0.065 | 0.045 | 0.055 | 0.087 | 0.073 | 0.079 | 0.065 |

Reactances shown are applicable to prime ratings.
 *Based on 30% voltage dip at 0.6 power factor.
 **With optional permanent magnet generator or AREP excitation.

| Voltage Technical Data 50 Hz | | | | |
|------------------------------|--------|-------|----------|-------|
| Voltage | Prime: | | Standby: | |
| | kVA | kW | kVA | kW |
| 415/240V | 135.0 | 108.0 | 150.0 | 120.0 |
| 400/230V | 135.0 | 108.0 | 150.0 | 120.0 |
| 380/220V | 135.0 | 108.0 | 150.0 | 120.0 |
| 230/115V | 135.0 | 108.0 | 150.0 | 120.0 |
| 220/127V | 125.0 | 100.0 | 138.0 | 110.4 |
| 220/110V | 135.0 | 108.0 | 150.0 | 120.0 |
| 200/115V | 135.0 | 108.0 | 150.0 | 120.0 |
| | | | | |
| | | | | |
| | | | | |

| Voltage Technical Data 60 Hz | | | | |
|------------------------------|--------|-------|----------|-------|
| Voltage | Prime: | | Standby: | |
| | kVA | kW | kVA | kW |
| 480/277V | 150.0 | 120.0 | 165.0 | 132.0 |
| 220/127V | 150.0 | 120.0 | 165.0 | 132.0 |
| 380/220V | 150.0 | 120.0 | 165.0 | 132.0 |
| 240/120V | 150.0 | 120.0 | 165.0 | 132.0 |
| 230/115V | 150.0 | 120.0 | 165.0 | 132.0 |
| 440/254V | 150.0 | 120.0 | 165.0 | 132.0 |
| 220/110V | 150.0 | 120.0 | 165.0 | 132.0 |
| 208/120V | 150.0 | 120.0 | 165.0 | 132.0 |
| 240/139V | 150.0 | 120.0 | 165.0 | 132.0 |
| | | | | |
| | | | | |
| | | | | |

Documentation

A full set of operation and maintenance manuals and circuit wiring diagrams.

Generating Set Standards

The equipment meets the following standards: BS5000, ISO 8528, ISO 3046, IEC 60034, NEMA MG-1.22.

FG Wilson is a fully accredited ISO 9001 company.

Warranty

All prime equipment carries a one year manufacturer's warranty. Standby equipment, limited to 500 running hours per year, has a two year manufacturer's warranty. For details on warranty cover please contact your local Dealer, or visit our website: FGWilson.com.

Dealer contact details:

FG Wilson has manufacturing facilities in the following locations:

Northern Ireland • Brazil • China • India • USA

With headquarters in Northern Ireland, FG Wilson operates through a Global Dealer Network.

To contact your local Sales Office please visit the FG Wilson website at www.FGWilson.com